

# THE AWR AUTOGUIDER TESTER

www.awrtech.co.uk/autotest.htm

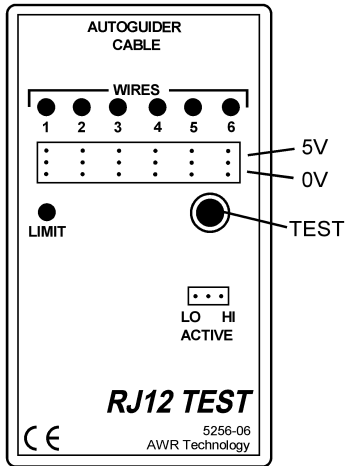

The **AUTOGUIDER TESTER** is a universal tool for 6 pin RJ12 connectors, used in autoguiding interfaces on a telescope or from a camera. Each of the six wires can be made a WEAK HIGH or LOW with a resistive pull (jumper selectable) or HARD HIGH or LOW again with jumpers. Finally there are LAMPS that tell the state of the lines (crude voltage monitors), Lamp ON is a HIGH (+5V) and lamp OFF is a logic LOW (0V).

## CONNECTION

Put in a PP3 battery and connect up the RJ12 lead to either the DRIVE BOX (into the AUTOGUIDER INPUT) or the CAMERA interface (REMOTE or AUTOGUIDER OUTPUT). Follow the setup instructions below for the device you are diagnosing. When you have set up the jumpers then press the TEST button and the lamps will light. The LIMIT lamp tells you if there is a higher current from the battery. The jumpers are shorting

links and so allow you to configure this device as a camera simulator or a telescope simulator. The 6 lamps indicate the activity. You need to find the four wires that have activity (the directions) and the common wire.

## TESTING AUTOGUIDER INPUT ON TELESCOPE DRIVE

The tester must be set up to mimic a camera. The camera switches a direction line to a HARD LOW to work with ACTIVE LOW signals. Some pinouts are in TABLE 1.

- 1) Remove the ACTIVE HI/LO jumper.
- 2) Try a jumper at each position on the block of 6 to find the common. The four direction lines will all be ON or OFF indicated by the lamps when you press the TEST button. The common is going to be one of the other two.
- 3) Use another jumper at each of the direction lines, press the TEST button, and make sure the telescope moves and note the direction. The jumper acts like a switch on a simple handset, only press (connect) 1 at once.

Now you have found all the information.

If you get the telescope to move with the second jumper to 5V then it is **ACTIVE HIGH INPUT**, if it is to 0V then it is **ACTIVE LOW INPUT**.

**TABLE 1. PINOUT OF TELESCOPE AUTOGUIDER SOCKET**

	1	2	3	4	5	6	ACTIVE
LX50/LX200	-	0V	LEFT	DOWN	UP	RIGHT	LOW
AWR	+5V	0V	E	S	N	W	LOW
QEI	W	E	S	N	-	0V	LOW
SS2K	-Y	+Y	0V	-X	0V	+X	LOW

**TABLE 2. PINOUT OF CAMERA AUTOGUIDER SOCKET**

	1	2	3	4	5	6	TYPE	ACTIVE
STAR2000 STD	-	0V	E	S	N	W	OPTO	LOW
ST7/8/9/...	-	0V	LEFT	DOWN	UP	RIGHT	TTL	LOW
PICTOR	+5V	0V	LEFT	DOWN	UP	RIGHT	TTL	LOW

**TABLE 3. ALTERNATIVE NAMES**

UP	N	DEC +	+Y
DOWN	S	DEC -	-Y
LEFT	E	RA +	+X
RIGHT	W	RA -	-X

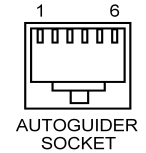

## TESTING REMOTE CONTROL OUTPUT ON CAMERA

The tester must be set up to mimic a telescope. The camera switches each direction line to a hard LOW or HIGH. Typical camera setups are shown in TABLE 2. The diagram shows a typical circuit for the ACTIVE LO condition.

- 1) Set up the ACTIVE HI/LO jumper.
- 2) Try ONE jumper in the block of 6, operate the camera directions (in set-up mode) and press the TEST button to see what shows. The lamps will tell you if any of the 4 direction lines are being operated by the camera. With the correct jumper position found for the common wire, the tester will show the four direction lamps operating when the camera requests them.

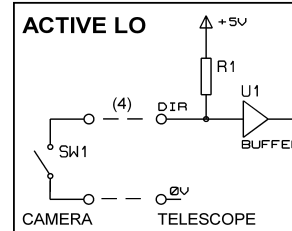

## TESTING OTHER INTERFACES

This unit can act as a breakout box and can be set up to monitor activity on other interfaces such as the Mead LX200 6 pin Serial lead for host computer. Connect the 0V jumper to pin number 2 and you should see serial activity on pin 5 from the computer or pin 4 from the drivebox. BRIGHT red = solid +ve, DIM red = activity, OFF = solid 0V

## SPECIFICATION

Resistive pulls	2.7 k ohm
Hard pulls	100 ohm
Operation	50 hours of use from a PP3
Battery	PP3, alkaline type recommended
Temperature range	-20 to +50 deg C
Socket	6 pin RJ12
Warning LIMIT lamp	20mA or above
CE marked	

## FURTHER INFORMATION ON THE WEBSITE!

www.awrtech.co.uk

Units are guaranteed for 1 year from purchase against defective materials and assembly.

In any query contact

### AWR Technology

The Old Bakehouse  
Albert Road, DEAL, Kent CT14 9RD  
01304 365918 +441304 365918

Manual V0.2 Apr 2007 8055-06B